

OS2 75

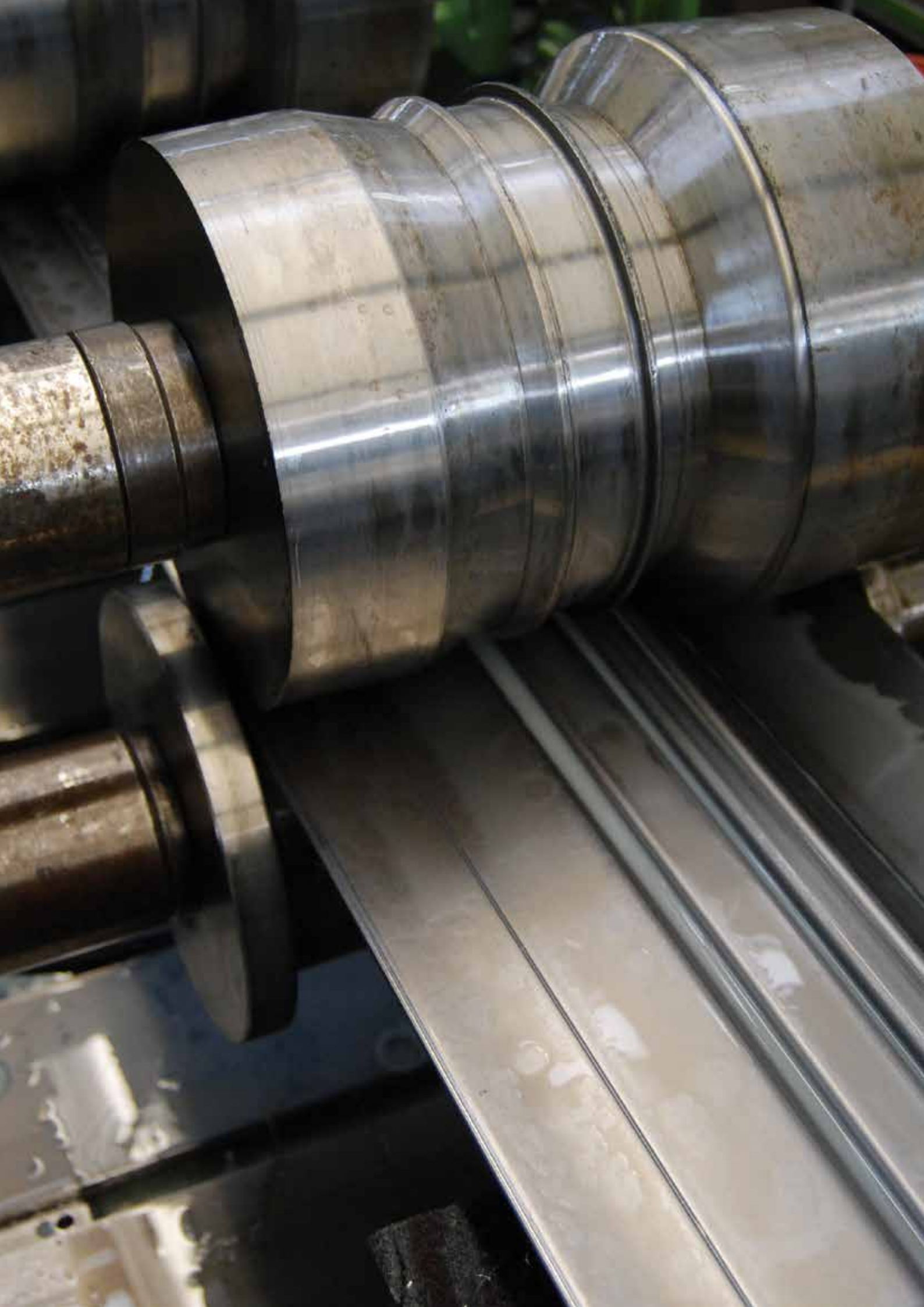

secco



With 70 years of experience, Secco Sistemi is the Italian leader in the production of integrated systems for doors, windows and façades in four different materials: galvanised steel, corten steel, stainless steel and brass. Every year 2 million metres of section bars are transformed into 200,000 finished elements. Fixtures are interpreted as part of an integrated and versatile system at designers' disposal blending industrial technology with craftsmanship creativity and attention to details.



OS2 75

applications

- doors
- windows

High-performing fixtures with minimised sections in high-end metals, with endless configurations of profiles and openings.

OS2 75 is part of the OS2 family, a system studied, designed and realised by Secco Sistemi to offer an alternative thermally broken solution to the steel fixture characteristic of the architecture from the 19th century to the 20s.

The OS2 thermally broken system is divided into three subsystems with a selection of over 40 different profiles providing minimum visible sections: from 27 to 62 mm.

The slim outline, in harmony with the research for transparency and pureness of shapes advocated in contemporary architecture, perfectly contrasts the heaviness of the masonry offering the freedom of maximising the glazing surface area. The endless variations of OS2 allow the designer to be in absolute control of the delicate play of light and shadow on both external and internal elevation being able to calibrate the fixtures till the smallest detail.

Compared to the first released of the system, **OS2 75** has introduced three new opening configurations: tilt&turn, pivot and bi-fold, steel maintaining the characteristic minimum sections and high performances of OS2.

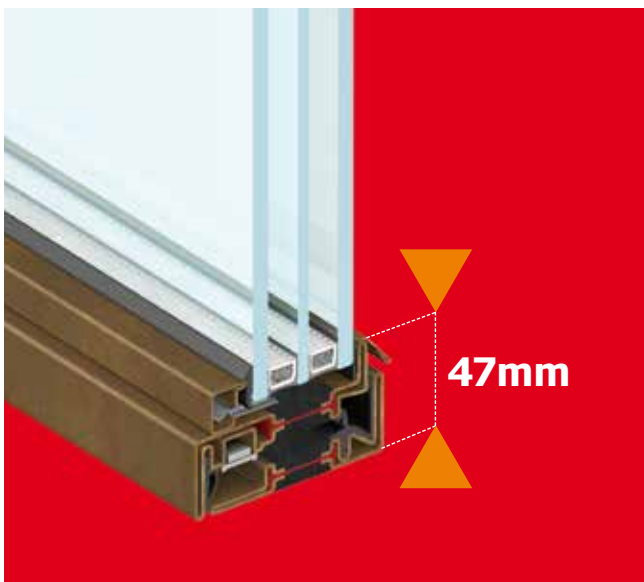

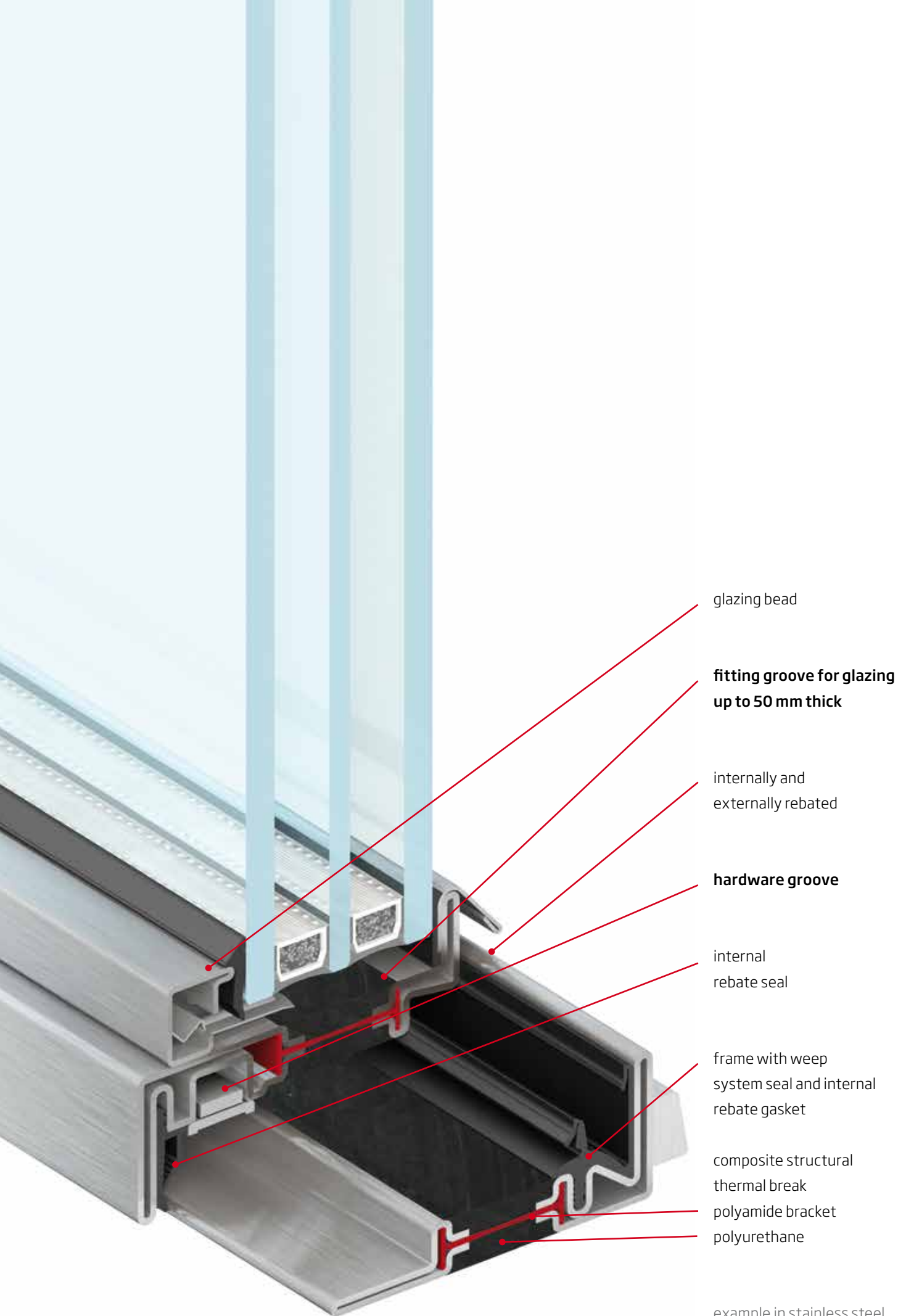

glazing bead

**fitting groove for glazing
up to 50 mm thick**

internally and
externally rebated

hardware groove

internal
rebate seal

frame with weep
system seal and internal
rebate gasket

composite structural
thermal break

polyamide bracket

polyurethane

example in stainless steel

OS2 75 materials

The materials used for OS2 systems are exclusively high-end metals - designed with careful attention to details as a result of constant research and monitoring - as for all complementary components of the system. Profiles in galvanized steel, stainless steel, corten steel and brass - in a wide range of finishes - offer prestigious fixtures which retain their value over time.

Galvanized Steel



- Galvanized Steel
- Painted Galvanized Steel

Due to the physical and technical properties of steel, thin, strong and high-performing profiles can be obtained which allow for maximum versatility in the design of the fixture while reducing the visual impact; the result is a lightness and transparency that provides elevated luminosity in the interiors.

The steel used by Secco Sistemi to produce its profiles is the alloy FeP02, with hot zinc covering G2200 (200 g /m3 on both sides) that ensures protection from oxidization both internally and externally. The subsequent skinpassing of the layer of zinc determines an ideal finish which guarantees better adherence during the painting process; this is carried out with polyester powder coating (oven-baked at 180° C) available in a range of colours, in gloss, semi-gloss and sandblasted versions.

Stainless Steel



- AISI 304 Satin
- AISI 316L Scotch-Brite
- AISI 316L Polished

As alloys based on iron, carbon, nickel and molybdenum, stainless steels do not rust if exposed to atmospheric agents, are extremely durable and resistant to corrosion, and need minimum maintenance. They can be recycled up to 90%. The physical-mechanical features of stainless steel mean that sections can be of reduced dimensions, thus lessening the visual impact of the fixture while enhancing the luminosity of the interiors. With thermal conductivity 10 times lower than aluminium, thermal break elements have a low transmittance value. Secco Sistemi uses two types of stainless steel to produce its sections: the more common 304 - with satin finish - and the 316L, ideal for maritime environments with scotch-brite or gloss finish.

Corten Steel



- Corten

The resistance of corten steel to corrosion is 6-8 times higher compared to traditional steels, as well as featuring double resistance to tensile strength, thus allowing the realization of high-performing fixtures of large dimensions and weight while maintaining the thinness of the sections. Special alloys obtained with copper, chrome and phosphorus, corten steels have the characteristic of self-protection with a patina on the surface that prevents corrosion from spreading and which gradually takes on colours and shades evoking the passing of time. Technological innovation and skill in interpreting the trends in contemporary architecture have led Secco Sistemi to be the first to use corten steel in the production of fixtures: elegant high-performing profiles, available in the 12 product lines and complete with accessories, can be realized also in corten steel with the desired finish and chromatic effect.

Brass



- Natural
- Burnished
- Polished

The colour and shininess of this alloy, together with the hardness and resistance to corrosion make it a precious and original element for architectural solutions in both old and new architecture. Surfaces in glossy or burnished brass can be an expression of luxury and refinement, or tradition. When this alloy comes into contact with the air it takes on the richness and the reflections of antique bronze while maintaining its physical properties intact. The natural oxidization determines a level of self-protection that makes the finished product ideal for using in difficult environmental conditions such as maritime settings. Secco Sistemi uses the alloy OT67 in which the high percentage of copper (67%) guarantees great resistance to corrosion, while the zinc (33%) improves the mechanical properties of hardness and breaking load. Another excellent product in terms of sustainability - re-usability is 100%.



OS2 75

design variations

OS2 75 with its many configurations and endless variations enhances the value of any architectural project designing fixtures in all their details, with the minimized sections and the high-performing characteristics of the OS2 system.



1. double leaf windows with congruent sections along the perimeter as well as the meeting stiles
2. screen with invisible openings



3. the screen presents congruent sections for both fixed and openable elements - SLD applied

4. the fixed pane is divided in two by a TLD presenting the same dimension on face of the frame

5. the screen presents a slim outer frame with a visible double leaf window at its center

6. the screen is characterised by uniformity and continuity, making the double leaf doors almost imperceptible except for the lock-box, feature of the system

OS2 75

opening types

OS2 75 offers a wide range of opening configurations which can be freely assembled in endless different combinations of seamless glazing panels. Various possible solutions, all tested and certified.

opening types

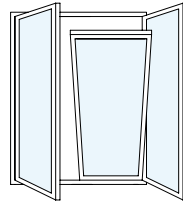

double leaf tilt
and turn window
w. 2000 | h. 2900 mm
RC2

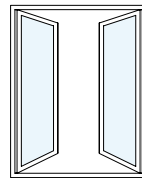

double leaf window
outward opening
w. 2000 | h. 2700 mm
RC2



double leaf door
outward opening
w. 2000 | h. 2700 mm

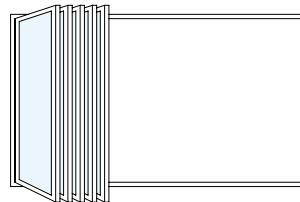

bi-fold window
inward opening
w. 5000 | h. 2900 mm

These have to be considered as maximum dimensions

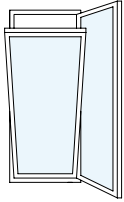

single leaf tilt
and turn window
w. 1300 | h. 2900 mm
RC2

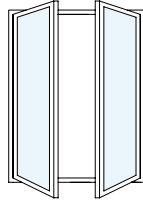

double leaf window
inward opening
w. 2000 | h. 2900 mm
RC2

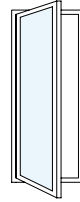

single leaf window
inward opening
w. 1000 | h. 2900 mm
RC2



bottom hung
window
w. 1300 | h. 800 mm
RC2

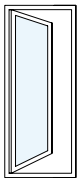

single leaf window
outward opening
w. 1000 | h. 2700 mm
RC2

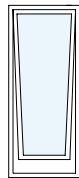

top hung window
w. 1000 | h. 2800 mm
RC2

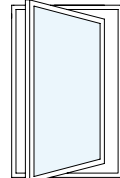

pivoting door
w. 1350 | h. 2700 mm
RC2

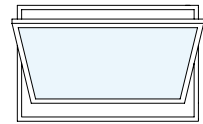

pivot windows
w. 2000 | h. 1400 mm
RC2

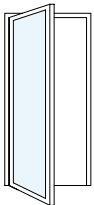

single leaf door
inward opening
w. 1000 | h. 2700 mm

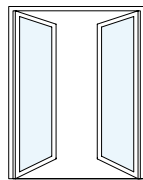

double leaf door
outward opening
w. 2000 | h. 2700 mm

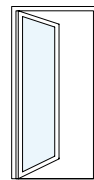

single leaf door
outward opening
w. 1000 | h. 2700 mm

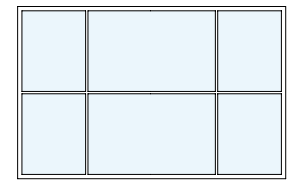

fixed frame

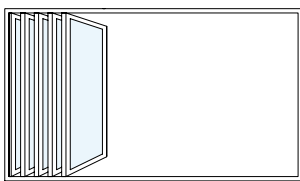

bi-fold window
outward opening
w. 5000 | h. 2900 mm

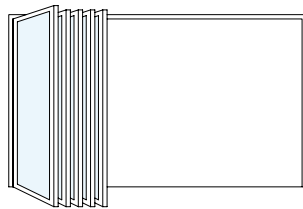

bi-fold door
inward opening
w. 5000 | h. 2900 mm

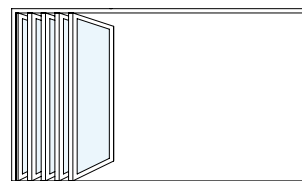

bi-fold door
outward opening
w. 5000 | h. 2900 mm

OS2 75

Window corners OS2 75



Window corner sample
OS2 75 in corten steel
with "Thin" glazing bead



Window corner sample
OS2 75 in stainless steel
scotch-brite squared
glazing bead

OS2 75 AR

tilt and turn windows

configuration examples



single leaf window
lateral and bottom section 47 mm



double leaf window
lateral section 47 mm | meeting stile 62 mm

OS2 75 with tilt&turn leaf represents a unique proposal for fixtures with minimized sections: thanks to an innovative design also large dimensions are feasible - up to 1300 x 2700 mm - while maintaining same excellent performances both in terms of sound and thermal insulation and offering glazing units up to 50 mm, concealed hinges and RC2 burglar resistance.

main sections

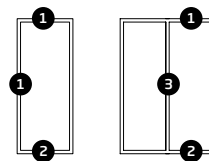
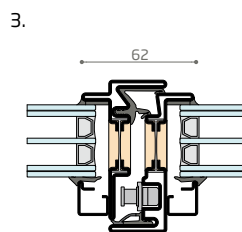
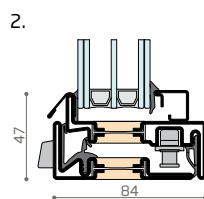
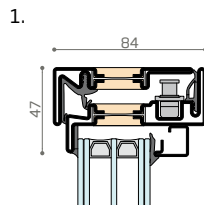

detail

opening types

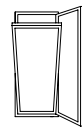
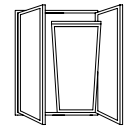
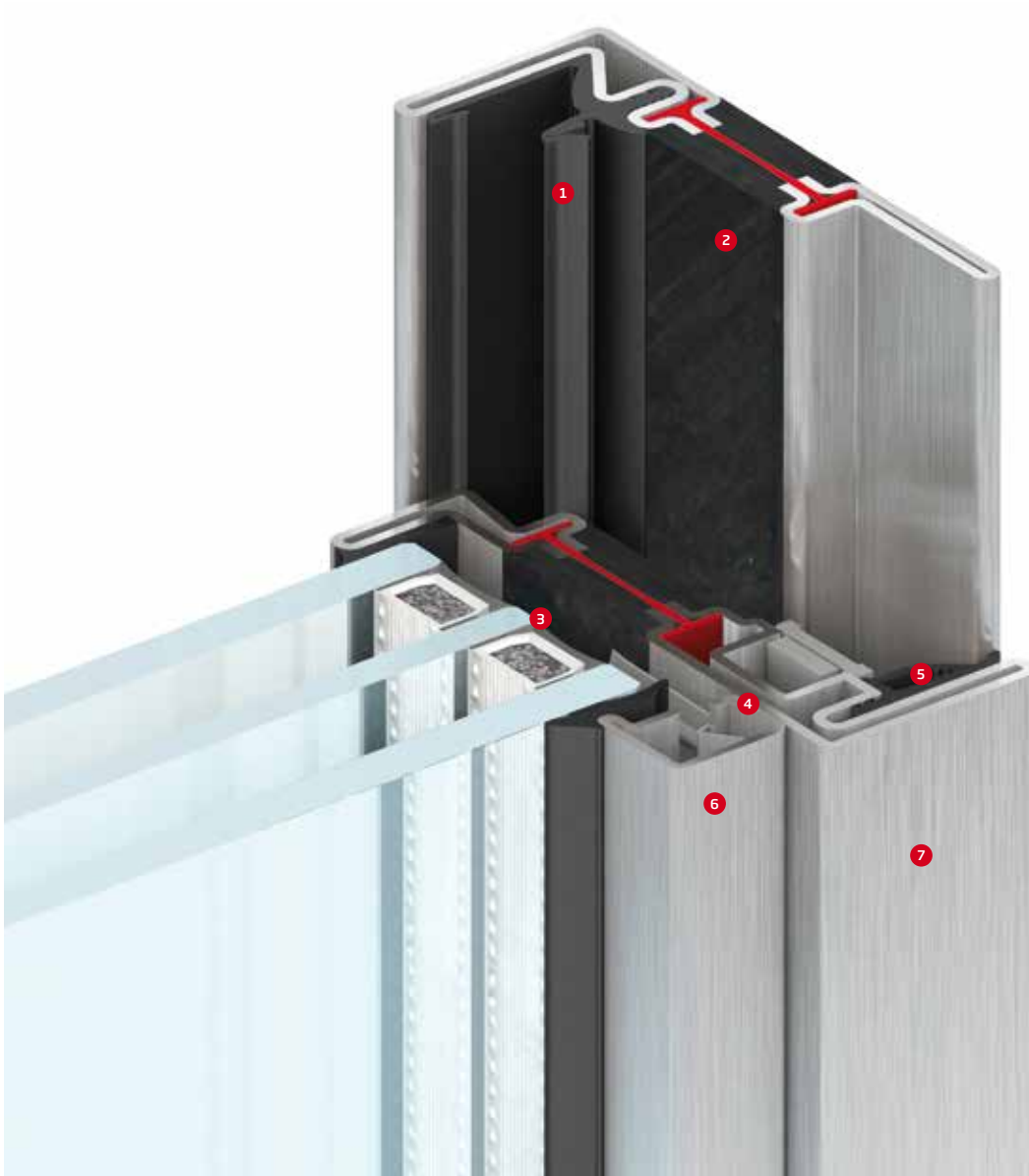

- ① frame with weep system seal and internal rebate gasket
- ② structural composite thermal break in polyurethane and polyamide
- ③ **fitting groove for glazing up to 50 mm**
- ④ **tilt and turn hardware groove**
- ⑤ internal rebate seal
- ⑥ glazing bead
- ⑦ internally and externally rebated

OS2 75 AR

Fondaco dei Tedeschi | Venice



An urban landmark on the Canal Grande in Venice, the imposing structure of the *Fondaco dei Tedeschi*, after decades of total abandon, has been given back to the city completely renovated by the masterly project of Rem Koolhaas. The original purpose of this building as a large warehouse as well as housing mercantile activity has been revived today, the brilliant vitality of which illuminates the

great facades with lights of windows shining night and day enhanced by the very fine Secco Sistemi OS2 profiles in natural brass.



OS2 75 L folding door

configuration examples



bi-fold door (max leaf width 1000 mm)
meeting stile 62 mm
close position

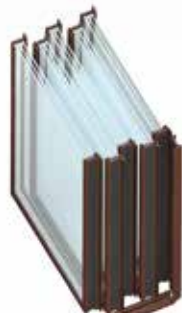

bi-fold door (max leaf width 1000 mm)
open position

OS2 75 folding leaves of large dimensions up to 1000 x 2900 mm with slim profiles and seamless frame interiors. A new thermally broken solution to interpret the transition from the interiors to the exteriors: the opened leaves offer reduced volumes thus increasing the interior spaces. Hinges, upper and lower tracks are concealed when the door is in close position.

main sections

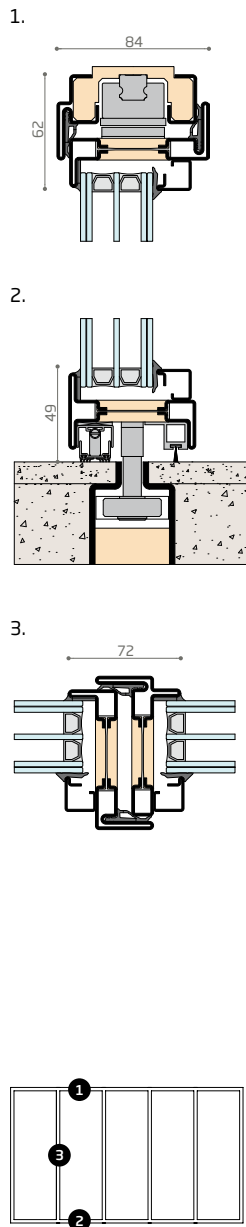

detail



- ① **stainless steel track**
- ② internally and externally rebated
- ③ external rebate seal
- ④ **fitting groove for glazing up to 50 mm**
- ⑤ composite structural thermal break in polyurethane and polyamide
- ⑥ glazing bead
- ⑦ internal rebate seal

opening types

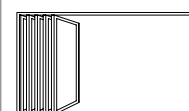
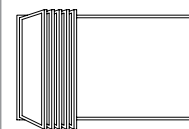

OS2 75 L

Villa Napa Valley | California



To design luxury interiors while maintaining the simple reassuring character of a great ranch, in a game that combines ostentation and reserve. The spacious living area of the villa is built using open and closed spaces: loggias and the transparent glazings of the steel OS2 windows to make up the wall panels.



OS2 75

main sections

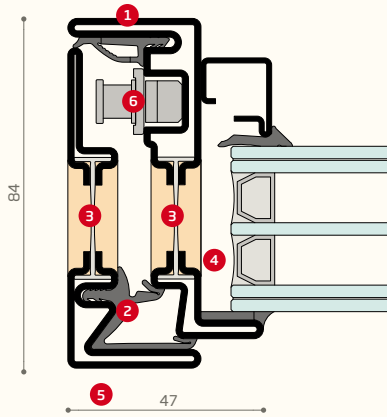

1. internally and externally rebated
2. weep system and double gasket
3. structural thermal break in polyamide and polyurethane
4. fitting groove for glazing up to 50 mm
5. section with reduced section
6. hardware groove

opening types

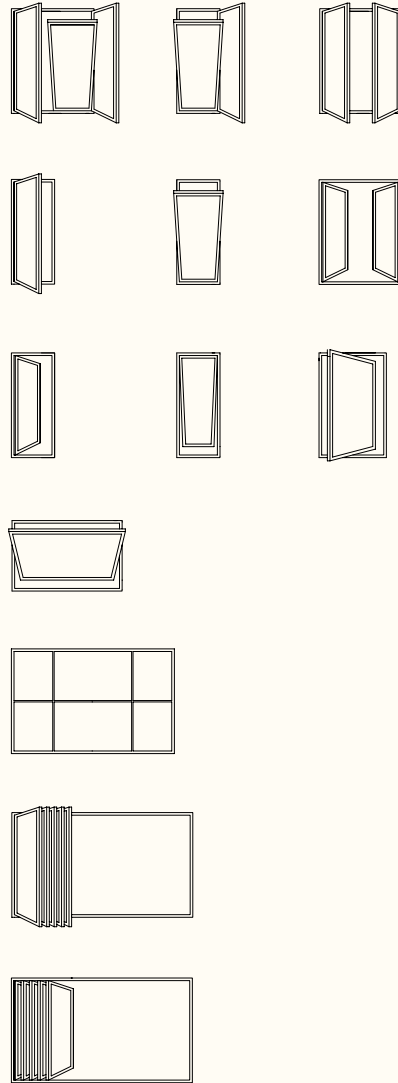

profiles

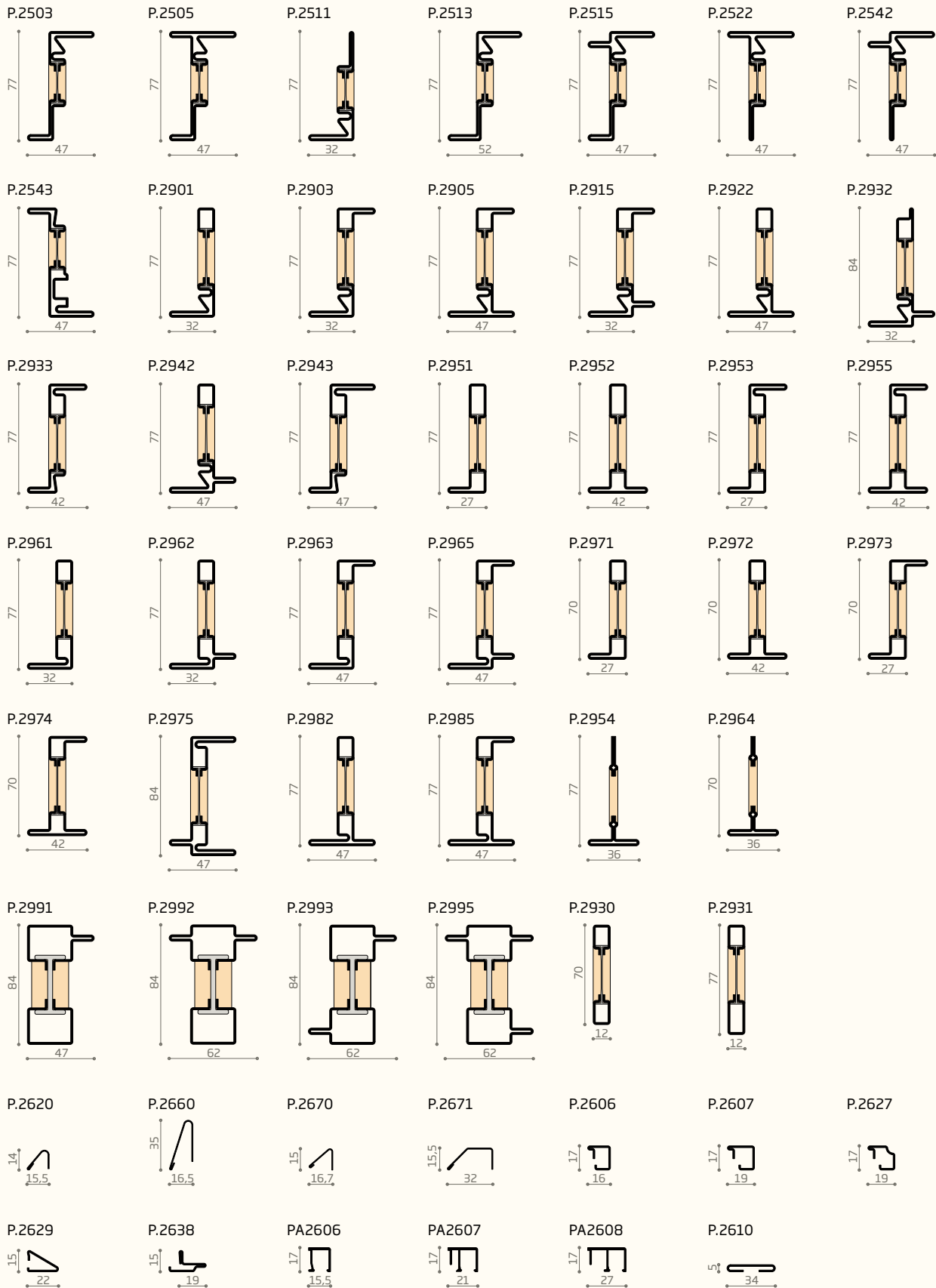

OS2 because

- tilt and turn opening
- bi-fold door
- pivot door
- 4 materials: brass, corten steel, stainless steel, galvanized steel
- lateral section 45 mm
- meeting stile 62 mm
- glazing up to 50 mm
- thermal transmittance down to 0.9 W/mqK
- concealed hinges
- burglar resistance RC2
- slim line



Secco Sistemi spa
via Terraglio 195
31022 Preganziol TV - Italy
tel. +39 0422 497700
fax +39 0422 497705
info@seccosistemi.it
www.seccosistemi.it